

WALTER

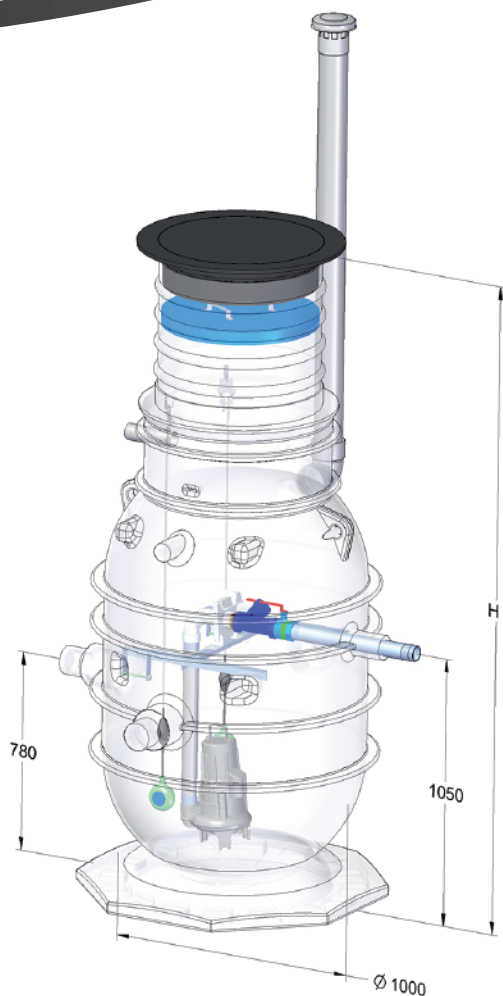

Compact pumping station „Walter“ is designed for waste-, drainage- and stormwater lifting in private or smaller house groups. Fast fitting enables fast and easy maintenance. Unique design gives durability and good anchoring.



SPECIFICATIONS:

- Cast \varnothing : 1000 mm
- Height H (with cover): H2000..3500 mm
- Inside pipes \varnothing : DN32, DN50
- Useful volume: 350 l
- Inlet pipes \varnothing : 110/160 mm
- Product is assigned a CE mark

OPTIONS

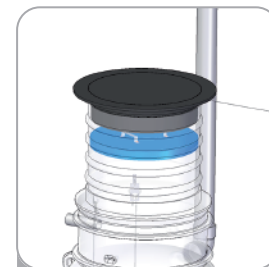

Cast iron cover (max 40 t)



Plastic lockable cover

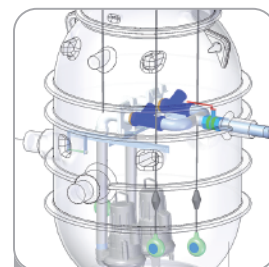

Insulation cast (50 mm) available for 1 pump or 2 pumps



Control unit with sound and light alarm. Monitoring possibility with GSM.

Inside „WALTER“ pumping stations we recommend you to use Flygt DX, SX, CF and MF serie pumps.

Product symbols:

- DX – serie name (wastewater- and drainage pumps)
- DXV – Vortex impeller.
- DXG – grinder pumps
- Flygt SX – serie name (stormwater,-and drainage pumps)
- SXV – Vortex impeller
- CF-C Shrouded single or multi-channel impeller pumps with large throughlets.
- MF-M Semi-open multi-channel impellers with integral grinder cutter.

	Pump model	Rated power kW	Max head m	Max delivery l/min	1-phase	3-phase	Delivery port
Drainage pumps	SX 2	0,25	7	145	230V	x	1¼"
	SXV 3	0,5	7	175	230V	400V	1¼"
	SX 3	0,5	11	225	230V	400V	1¼"
	SX 5	0,5	10	275	230V	400V	1½"
	SX 7	0,7	15	350	230V	400V	1½"
	SX 11	1,1	17	375	230V	400V	1½"
	SX 15	1,5	21	410	x	400V	1½"
Wastewater pumps	DX 35-5	0,55	10,5	300	230V	400V	1½"
	DX 50-7	0,75	10,25	540	230V	400V	2"
	DX 50-11	1,1	12,8	615	230V	400V	2"
	DX 50-15	1,5	14,5	700	x	400V	2"
	DXV 35-5	0,55	9	300	230V	400V	1½"
	DXV 50-7	0,75	7,7	540	230V	400V	2"
	DXV 50-11	1,1	9	615	230V	400V	2"
	DXV 50-15	1,5	11,2	700	x	400V	2"
Grinder pumps	DXG 25-11	1,1	24	138	230v	400V	1"
	DXGM 25-11	1,1	24	138	230v	400V	1"
Large wastewater pumps	CF 3045	0,75	8,5	510	230v	x	2"
	CF 3045	1,2	13,2	630	x	400v	2"
	CF 3057	1,5	17	840	230v	x	2"
	CF 3057	2,4	24	660	x	400v	2"
Large grinder pumps	MF 3068	1,5	19	264	230v	x	1½"
	MF 3068	2,4	31	288	x	400v	1½"

